

The Sodium-Ion Paradigm Shift

Uncompromising Power, Safety,
and Longevity for Modern Vehicles

Technical Briefing Dossier | StratoForse Series

The Starting Battery Dilemma

Lead-Acid (AGM)



The Benefit:

Known safety and low upfront cost.

The Compromise:

Heavy (30–50 Wh/kg), short cycle life (<700 cycles), struggles in extreme cold, and requires frequent replacement.

Lithium (LFP/NMC)



The Benefit:

Lightweight and high energy density (120–300 Wh/kg).

The Compromise:

Susceptible to **thermal runaway** (fire risk), **expensive**, and narrow safe operating temperature windows.



Historically, fleet managers and automotive professionals had to choose between safety and performance.

The Sodium-Ion Breakthrough

Introducing Polyanionic Sodium-Ion ($\text{Na}_4\text{Fe}_3(\text{PO}_4)_2(\text{P}_2\text{O}_7)$) – NFPP.



1 Clean Origin

Energy derived from one of the most abundant and clean materials on the planet: Salt.

2 Zero Heavy Metals

Eliminates the need for expensive, volatile, or toxic transition metals.

3 The Ultimate Balance

Delivers the high-performance cranking power of Lithium with a safety profile superior to Lead-Acid.

The Definitive Comparison Matrix

	Lead-Acid (AGM)	Lithium (LFP/NMC)	Sodium-Ion (NFPP)
Cycle Life	>700 	2500-6000 	>5000 
Thermal Stability / Fire Risk	Good 	Poor/Moderate 	Excellent/Zero Risk 
Operating Temp Range	Poor extremes 	Poor cold / Good hot 	-30°C to +80°C 
0V Dead-Flat Recovery	No 	No / BMS Lockout 	Yes 
Weight Profile	Heaviest 	Lightest 	60% Lighter than Lead 

Takeaway: Sodium-Ion (NFPP) sweeps the critical categories for automotive application, bridging the performance gap without the catastrophic failure points of Lithium.

Uncompromising Safety & Extreme Climates

The Thermal Window Thermometer



1

Zero Thermal Runaway

Highly stable NFPP cathode structure prevents fire, even under stress.

1

2

Non-Toxic & Acid-Free

No corrosive spills, no dangerous gas venting (H₂ or CO₂).

2

3

IP65 Sealed

Completely maintenance-free and secure from environmental ingress.

3

The 0V Recovery Superpower

The 0V Bounce-Back Graph

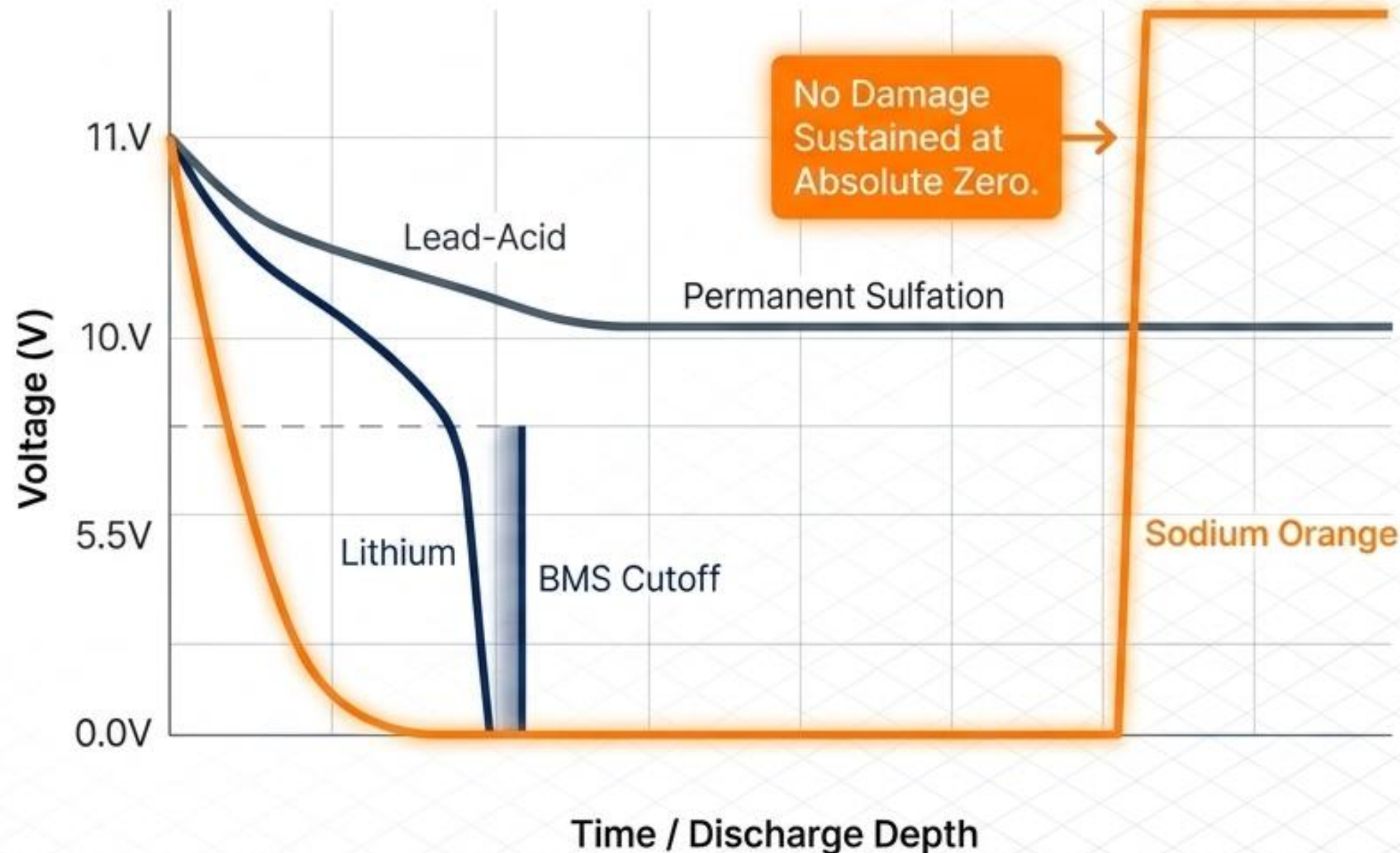

Dead-Flat Recovery

0 Volts

Can be drained to 0% SoC and fully recovered without severe capacity loss.

Massive Cycle Life

3,000 Cycles

Up to 3,000 cycles at 50% Depth of Discharge.

Engine Starts

180,000

Built to survive extreme start-stop demands.

The Economics of Longevity (TCO)

TCO Timeline Comparison

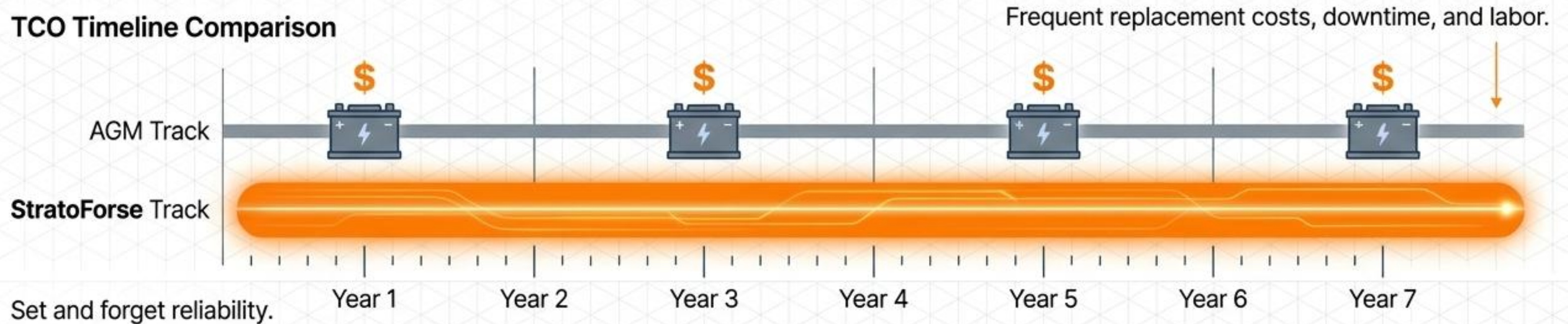

Standard Confidence

36-Month Warranty

On standard StratoForse lines.

Premium Assurance

5-Year Warranty

On StratoForse-SS+ (Stop-Start models).

Bottom Line Insight: Upfront investment is rapidly offset by eliminating replacement cycles, saving fleet managers thousands in hardware and labor downtime.

How It Works: The Na+ Engine

① **Positive Electrode:** Polyanionic compounds (NFPP) ensuring structural rigidity and safety.

② **Negative Electrode:** Hard carbon for highly efficient ion absorption.

③ **Electrolyte:** NaPF₆, a stable conductive fluid.

④ **Current Collectors:** Aluminum foil on BOTH sides.

Eliminates the need for expensive, heavy copper.

During charge/discharge, Sodium ions shuttle back and forth. Transition metals in the positive electrode gain/lose electrons, ensuring massive energy flow without degrading the structural integrity of the cell.

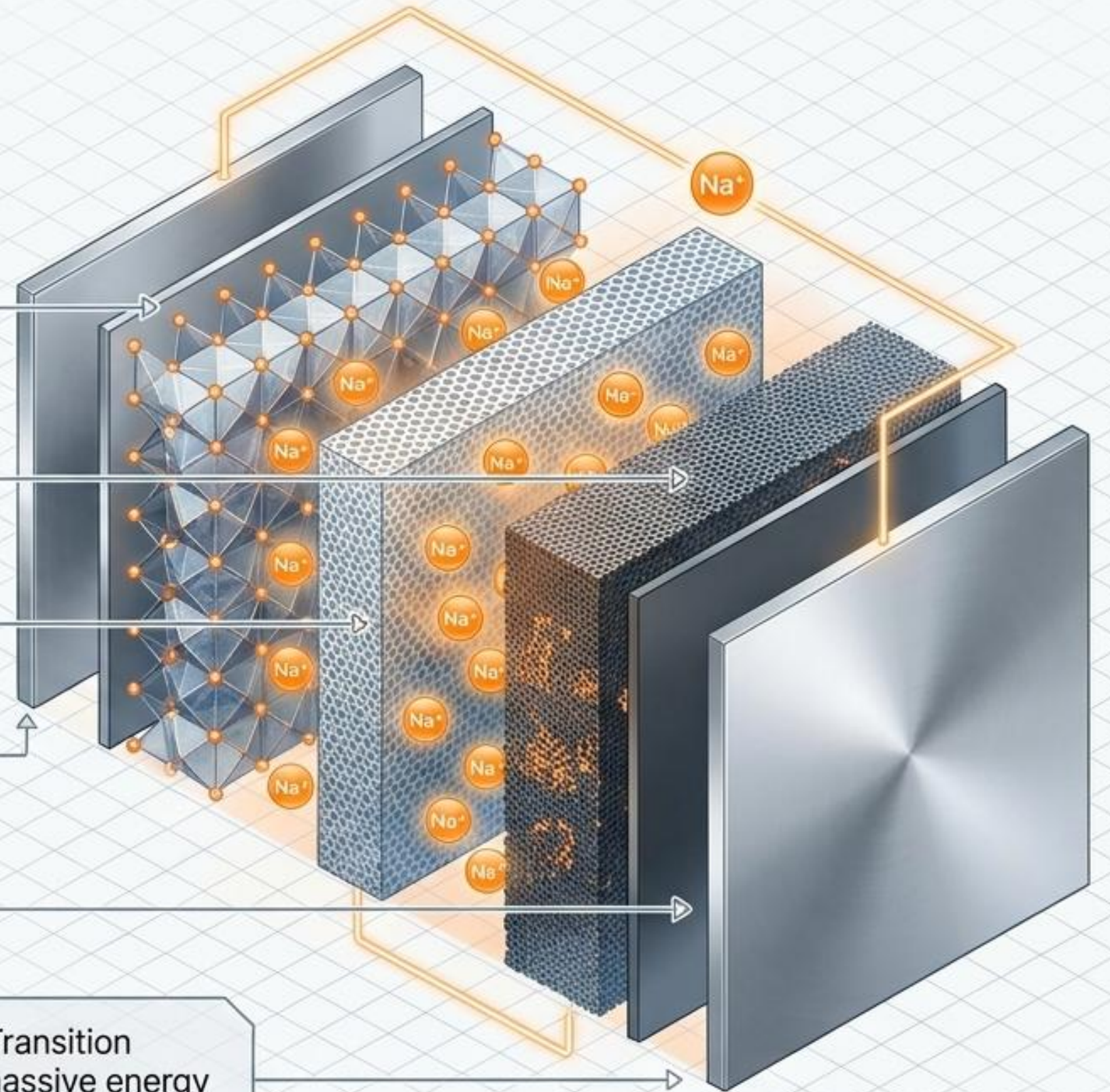

The StratoForce Architecture

1. PC+ABS Container

High-impact, flame-retardant shell designed for extreme vibration resistance.

2. The Core

4 Sodium-Ion cells in series (2.85V per cell) for 12V packs; 8 cells for 24V packs.

5. Terminals

High-conductivity Copper/Aluminum blend.

4. Automatic Fuse

Integrated circuit break protection during extreme current events.

3. Internal Fixation Kit

Rigid holding structure and control bar to eliminate internal movement.

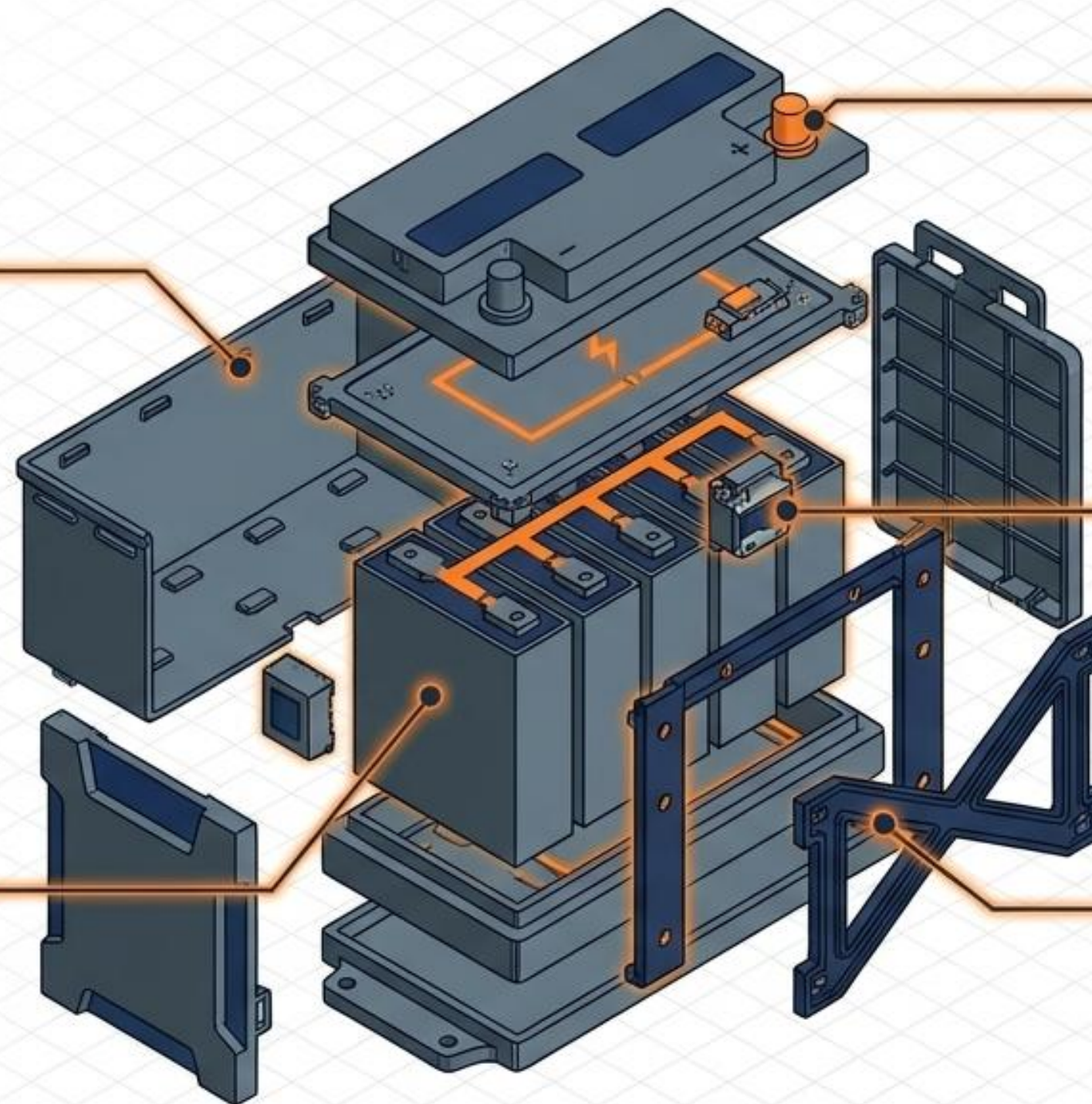

The Passenger Powertrain Ecosystem

StratoForse (Start Battery)

Target: Standard automotive cranking.

Up to
650 CCA
(95D31L)

120,000
Starts

2,700
Cycles

StratoForse-SS (Stop-Start)

Target: High-demand Stop-Start systems.

Up to
950 CCA
(H9/LN6)

180,000
Starts

3,000
Cycles

StratoForse-SS+ (Premium)

Target: Maximum capacity & endurance.

850 CCA

Extra 10Ah
Capacity

5-Year
Warranty

Universal Specs



1C Fast Charge



60% Lighter than AGM



Standard JIS & SAE Fitments

Commercial Heavy-Duty: StratoForce-24V

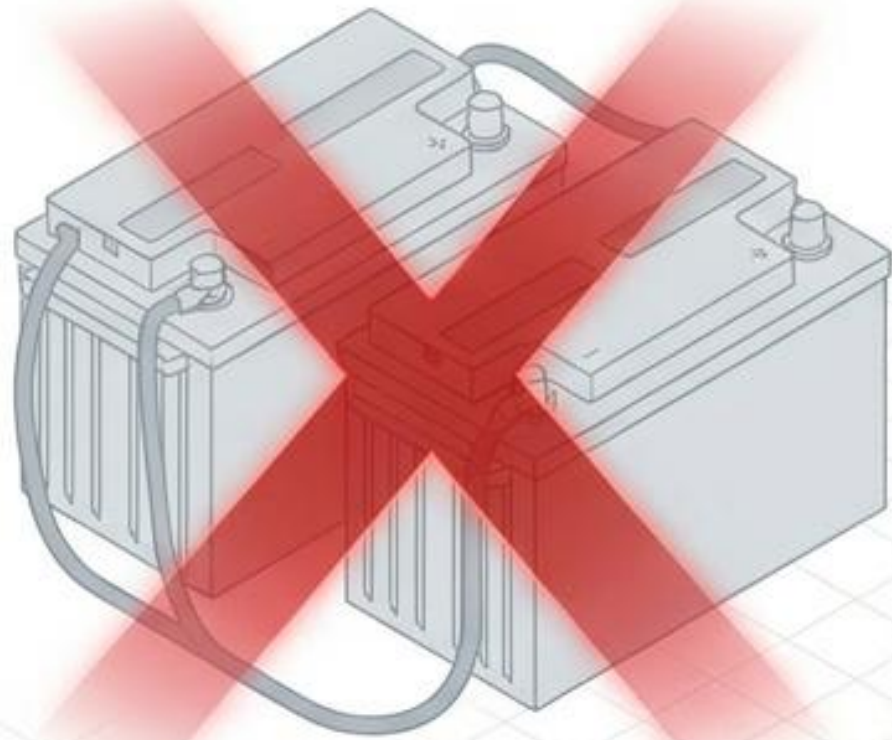

The All-In-One 24V Replacement

Replaces cumbersome 2x12V parallel/series setups with a single, highly efficient 24V pack.

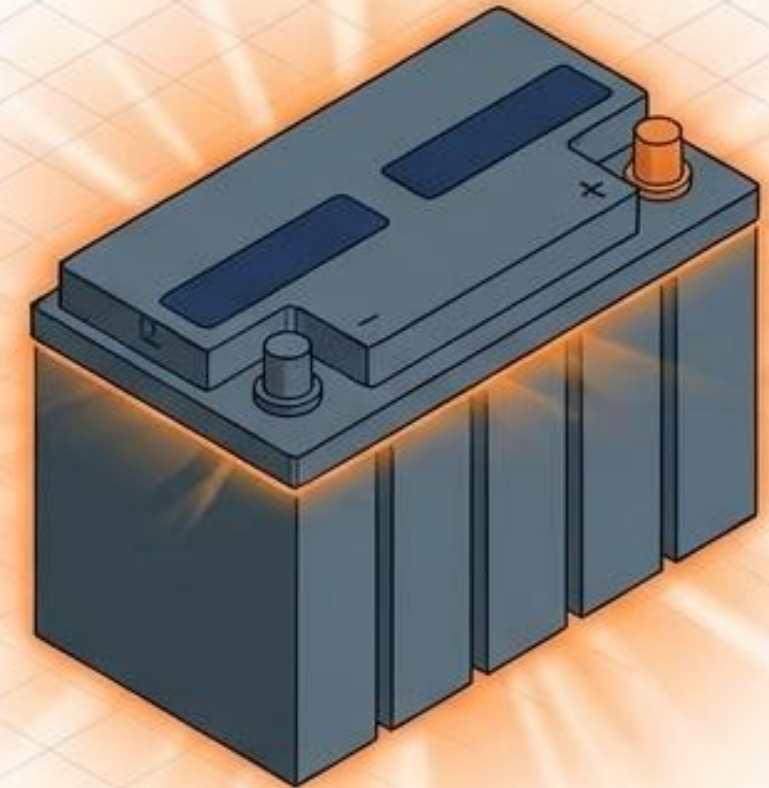

Energy:

960 Wh

High-density capacity.

Cranking Power:

850 CCA

1000 Marine Cranking Amps (MCA)

Extreme cold & marine starts.

Weight:

Only 12.0 kg

(Massive weight reduction for commercial fleets)

Durability:

Vibration resistant
36-Month commercial warranty.

Built for rigorous commercial use.

Seamless Drop-In Integration

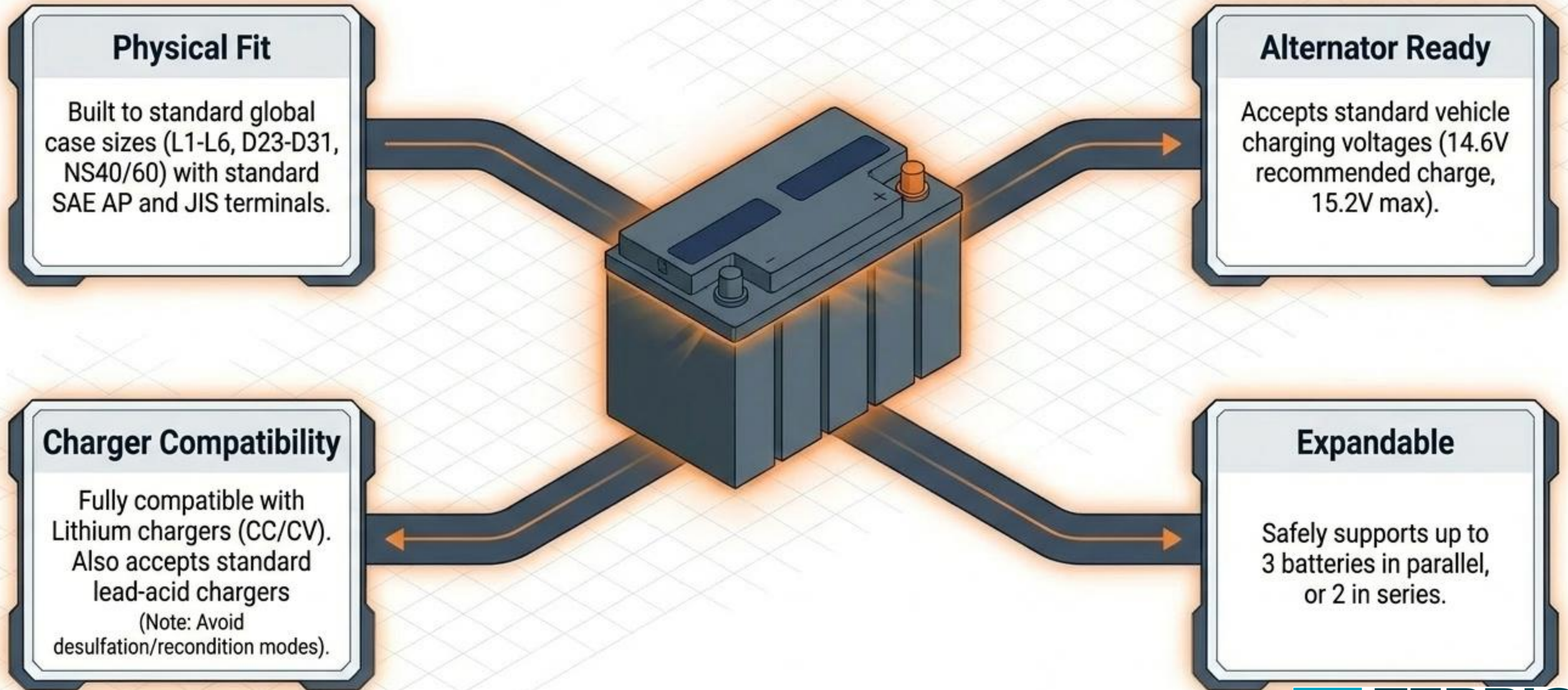

Shattering the Trilemma

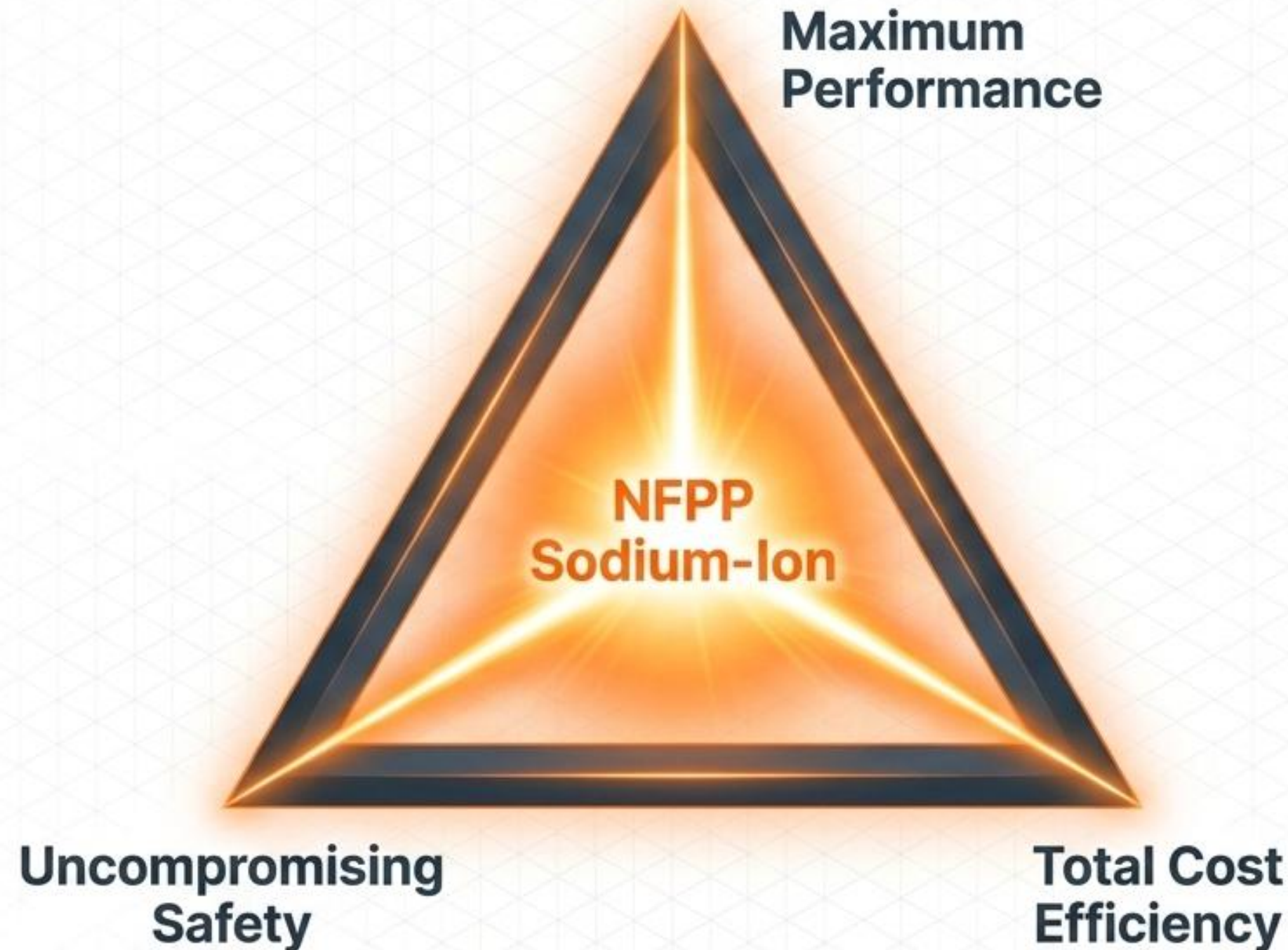

For decades, the automotive industry accepted a compromise: safe and cheap, or powerful and risky.

The Polyanionic Sodium-Ion chemistry of the StratoForce series shatters this paradigm. It offers **Lithium-tier fast-charging** and cranking power, alongside **Lead-Acid-tier safety** and thermal stability, ultimately delivering the **lowest Total Cost of Ownership** on the market.

Upgrade Your Powertrain Today.

Secure your fleet's reliability with next-generation Sodium-Ion technology.

Available in standard automotive, stop-start, and heavy-duty 24V commercial formats.

Terrion Energy Solutions

Website:

<https://terrion.com.au/>

Sales & Technical Support:

info@terrion.com.au

CE-EMC, UN38.3, IEC61000 Certified Technology. Evaluated for excellence.